

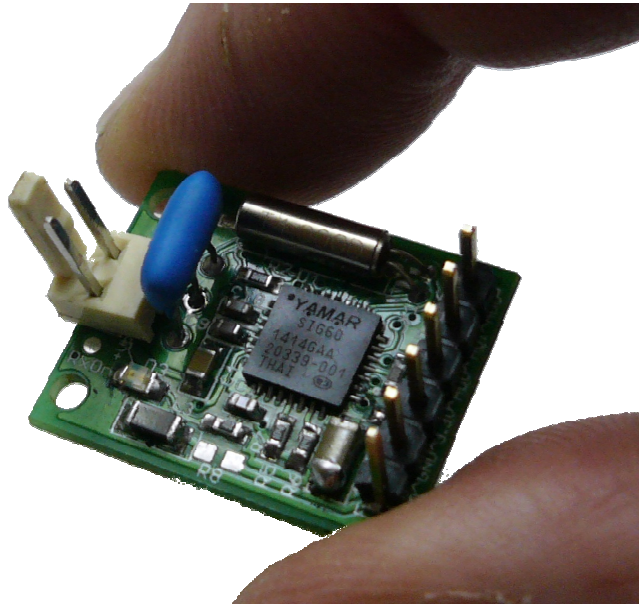

17 Shimon Hatarsi St.  
Tel Aviv, 62492 Israel  
Tel: (972) 3-544 5294  
Fax:(972) 3-544 5279

# SIG60 Micro Module Manual



*The information, data and drawings embodied in this document are strictly confidential and supplied on the understanding that they will be held confidentially and not disclosed to third parties without the prior written consent of YAMAR Electronics Ltd.*

### Revision History

| Revision | Issue Date | Comments          |
|----------|------------|-------------------|
| 0.2      | 11.11.2014 | Updated schematic |
| 0.202    | 28.5.2015  | Updated schematic |
|          |            |                   |
|          |            |                   |
|          |            |                   |
|          |            |                   |
|          |            |                   |
|          |            |                   |
|          |            |                   |

技术 & 商务联系方式: 南频科技有限公司  
陈小姐 业务工程师 156 2521 4151  
rita.chen@dwintech.com www.dwintech.com  
座机0755-82565851

## 1. GENERAL

The SIG60 Micro module provides the basic circuitry for operating the SIG60 device in a system. Multiple SIG60 Micro modules can communicate over a vehicle's DC power line using the UART interface. Network example is presented in Figure 1.1. The SIG60 Micro module operates as a DC powerline transceiver. The SIG60 transfers any number of bytes over the powerline to all other SIG60 devices on that line. One of the devices should be used as a Master to avoid collisions on the powerline operating as a network.

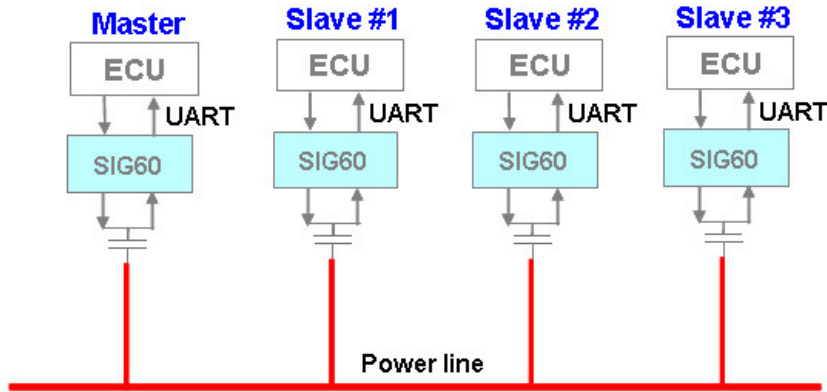

Figure 1.1 - System configuration example

## 2. SIG60 Micro Module Description

### 2.1. Module

The Micro module contains the required hardware for the SIG60 operation on a single 6.5MHz channel, the 4MHz crystal, line protection network, 6.5MHz ceramic filter, 5V-12V DC linear power supply for the 3.3V required for the device operation.

The SIG60 operates as a UART transceiver, using its HDI input and HDO output pins. The HDC pin allows access to the internal registers. See SIG60 data sheet for detailed information. The default bit rate of the device is 19.2Kbps. Bit rates of 9.6Kbps, 38.4Kbps and 57.6Kbps can be used by programming the internal registers.

The SIG60 may also be used as a new physical layer to the LIN protocol. The Micro module is designed to interface directly with any host Micro controller with a UART port via the J2 6 pins header.

The connection to the powerline is via J1 connector. It is possible to connect to the powerline via J2 if a 0 ohm resistor is installed on R8. In such case special care should be taken to avoid the possibility that the 12V input will be accidentally connected to any of the other pins.

### 2.2. Signals

The received modulated signal from the DC line passes through a protection network into the RxIn input pin to an Rx amplifier inside the SIG60. The amplified signal passes via F1B pin to 6.5MHz external ceramic filter and back into RxP input. The SIG60 decodes the data and output the decoded UART data to HDO pin as an asynchronous bit stream.

On the transmitter side, the host uC sends UART data to the SIG60 via HDI pin. The asynchronous data is protected inside the Sig60 against errors and modulated. The DTXO pin outputs the digitally modulated signal to the ceramic filter for shaping via R1. The shaped signal enters back into the SIG60 via F1B pin to an output amplifier. The modulated data on TxO pin drives the DC line via the protection network.

技术 & 商务联系方式: 南频科技有限公司  
 陈小姐 业务工程师 156 2521 4151  
[rita.chen@dwintech.com](mailto:rita.chen@dwintech.com) [www.dwintech.com](http://www.dwintech.com)  
 座机0755-82565851

## 2 .3. Hardware

The Micro module contains:

- SIG60 DC Power Line Communication device
- UART serial header
- 6.5MHz ceramic filter
- 4MHz crystal
- 6V to 12V Linear power supply
- Small size PCB

### Connectors:

J2 – Host interface.

J1 – DC line connector.

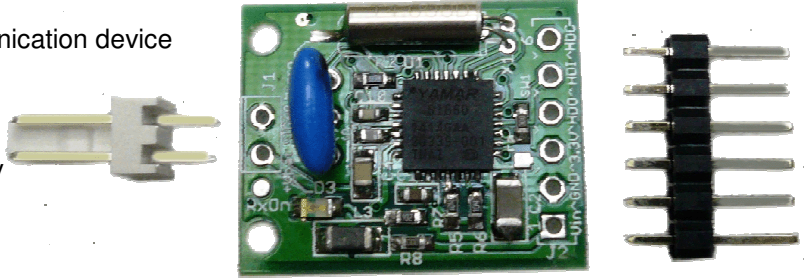

## 3. Operation

### 3 .1. Configuration

The SIG60 mode of operation and its settings are configured at power-up, reset and whenever the Host writes into its internal register. Refer to SIG60 data sheet for further configuration information.

### 3 .2. Connectors

#### 3.2.1. JP1 – Host Interface Connector

| Pin Name                  | Direction | Pin # |
|---------------------------|-----------|-------|
| Vin (Vbat after inductor) | O         | 1     |
| Ground                    | P         | 2     |
| 3.3V                      | I         | 3     |
| HDO (data out)            | O         | 4     |
| HDI (data in)             | I         | 5     |
| HDC                       | I         | 6     |
| Ground                    | P         | 13    |

*All input and output signals are compatible with 3.3V CMOS logic.*

#### 3.2.2. JP2 – DC Power Line and test points

| Name               | Pin # |
|--------------------|-------|
| GND                | 1     |
| VBat DC line input | 2     |

VBat input connects the module to the DC power line for communication and power supply.  
Power supply requirements: 6V to 12V, 80mA.

技术 & 商务联系方式: 南频科技有限公司  
陈小姐 业务工程师 156 2521 4151  
rita.chen@dwintech.com www.dwintech.com  
座机0755-82565851

### 3 .3. Interfacing

The SIG60 module is designed to interface directly to any controller with UART port.

Three signals are essential for proper operation; HDI, HDO and GND (Data In, Data Out and Ground). The use of HDC pin is required only if the device should be used in different bit rate or mode of operation.

The Figure below is an example for an interface. It is recommended to add an inductor of at least 22uH (or bead with high impedance at 6.5MHz) between the SIG60 evaluation board and the Micro controller (uC) supply line to avoid possibility that the uC power supply filtering capacitor will short the SIG60 carrier signal.

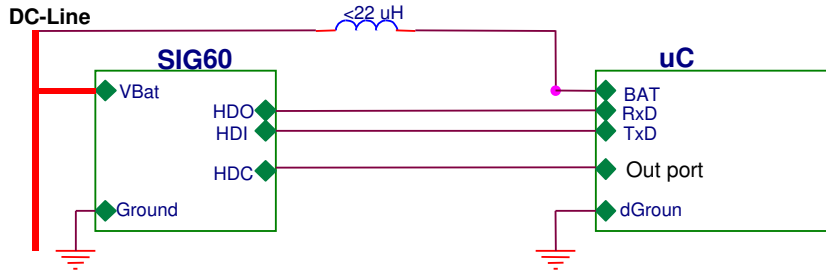

Figure 3.1 – SIG60 Module Interface with a Host.

### 3 .4. Operation

1. Connect the communication signals via JP2 to the host uC.
2. Connect the Micro module to the DC Power line.
3. When using the default values (6.5MHz, 19.2Kbps) there is no need for any configuration. Changing the SIG60's default values is possible by lower the HDC input pin and writing to the SIG60's registers the new bit rate and mode of operation as described in the SIG60's datasheet.
4. Raise the HDC input and start UART communication.
5. Transmit and receive UART data bytes to and from remote host over the DC power line.

技术 & 商务联系方式: 南频科技有限公司  
陈小姐 业务工程师 156 2521 4151  
rita.chen@dwintech.com www.dwintech.com  
座机0755-82565851

### 3.5. SIG60 Micro module Schematic

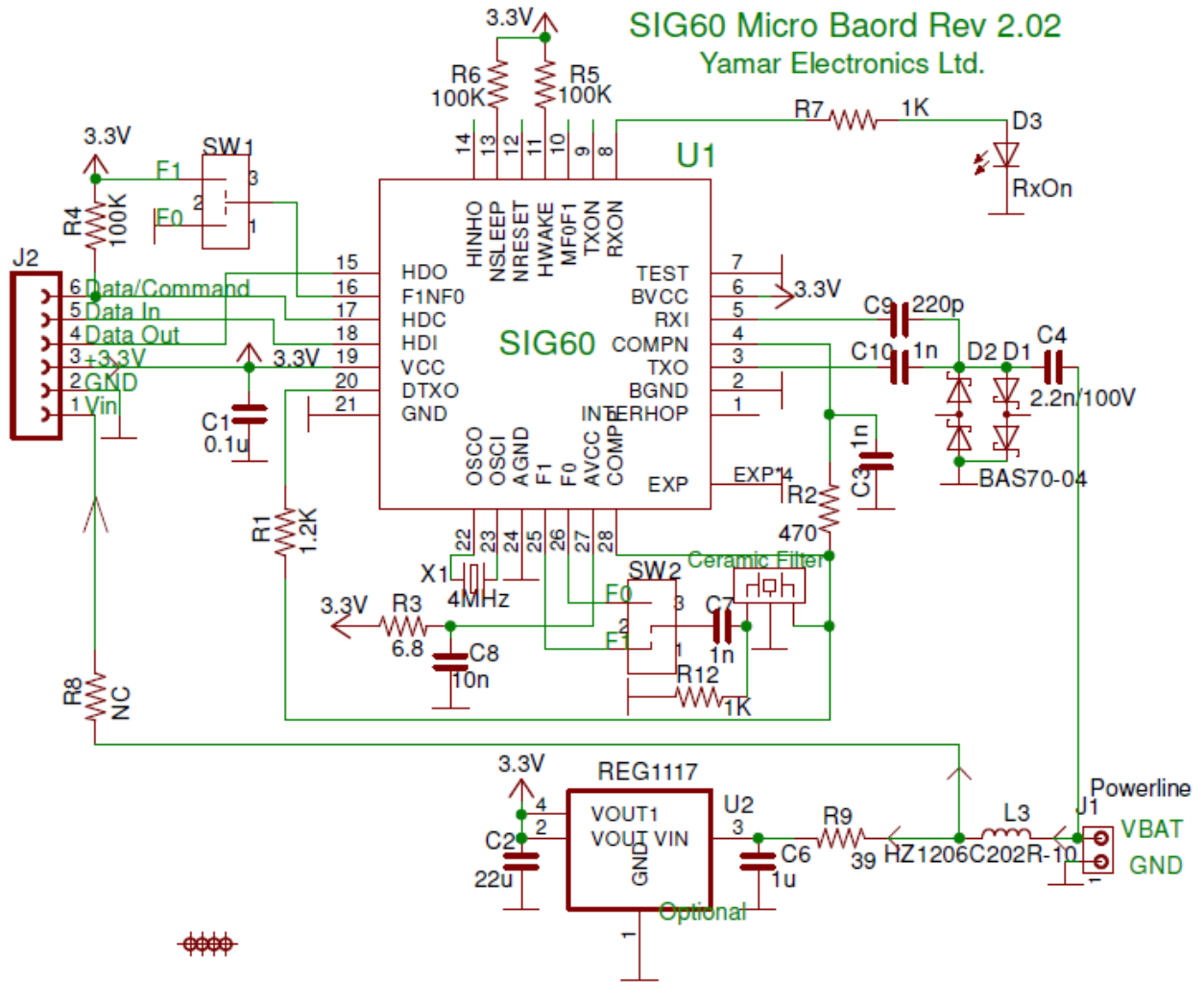

Figure 3.2 - SIG60 Rev 2.02 Schematic

### 3.6. Micro module layout

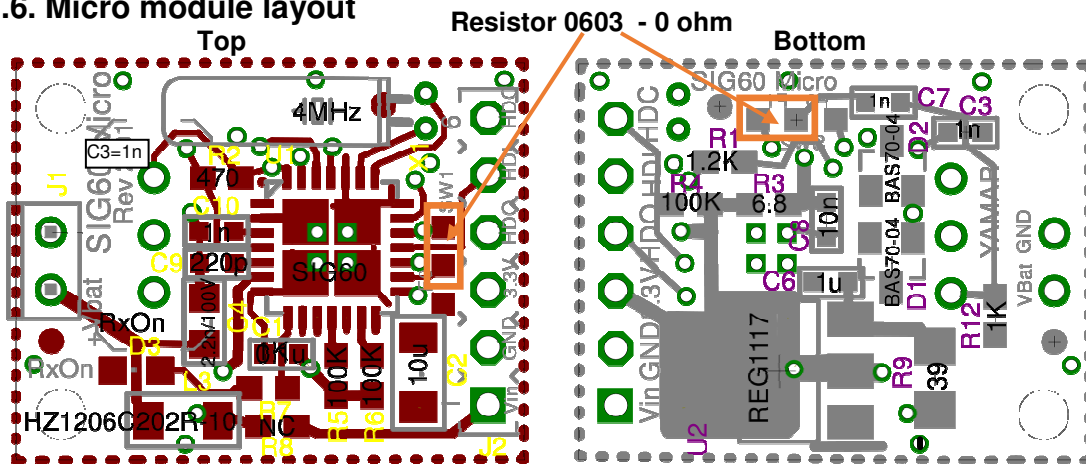

Figure 3.2 - Module Layout