

XIDAS IOT

VEG

**Vibration-Based
Energy Harvesting
Generator**

99000001-A0

Introduction

The VEG series of vibration-based energy harvesting generators utilize novel electromagnetic technology to convert small vibrations in the environment (such as industrial machinery) into electrical energy. Even at low vibration profiles of sub 100 Hz and sub 1g accelerations, these industry-first energy harvesters can generate 10+ mW of power! By leveraging decades of 3D manufacturing research, Xidas delivers a highly cost-effective solution to the IoT market's biggest issue: battery life.

Leading sensor manufacturers have all started introducing wireless versions of their sensors. Additionally, new IoT companies are emerging that leverage advances in MEMS transducers and couple them with edge intelligence and big data analytics to provide application specific solutions. All these wireless devices must balance what the edge device does with how much power capacity the battery can provide. Wireless sensor lifetime, or battery lifetime becomes the most critical selling criteria for Wireless IoT products, particularly for industrial or B2B applications as the cost of replacing batteries is substantial. Hence...the need to incorporate energy harvesting solutions.

Xidas offers a range of VEG models that are designed for 20 Hz (VEG-20), 30 Hz (VEG-30), 50 Hz (VEG-50), 60 Hz (VEG-60), and 70 Hz (VEG-70). It is important to understand what the common resonant frequency is of the vibrating source you will be mounting on. For other target resonant frequencies, please consult with the factory.

These units are offered with the intent to be designed within your wireless sensor enclosure. Including the VEG energy harvesting inside your wireless product can increase your solution's lifetime to 10+ years!



Size of VEG compared to a D-Cell battery



Specifications

Electrical Output	20 V max peak-to-peak (w/ 440 ohm)
Power at 0.1 g's resonance	1mW (typ)
Power at 0.2 g's resonance	4mW (typ)
Power at 0.5g's resonance	18mW (typ)
Max Acceleration	0.9 g
Output Impedance	440 ohm 24 mH @ 1 kHz (typ)
Dimensions	52mm dia. x 24mm
Mass (maximum)	90 g
Operating Temperature	-40°C to+85°C
Life	> 10 years
Coil Resistance	435 Ω

Dimensions (millimeters)

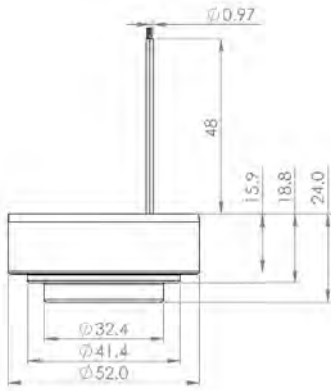

(a) Shows the side profile.

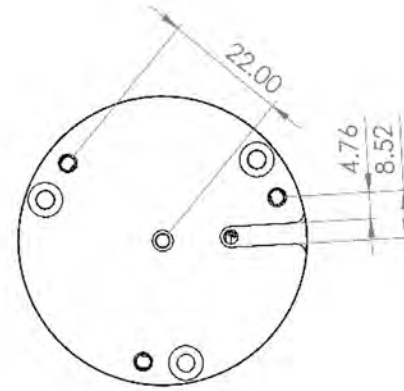

(b) Shows the bottom profile.

Power Output (Energy Generation)

The following graphs shows the maximum power which can be drawn from the generator when applied to a resistive load.

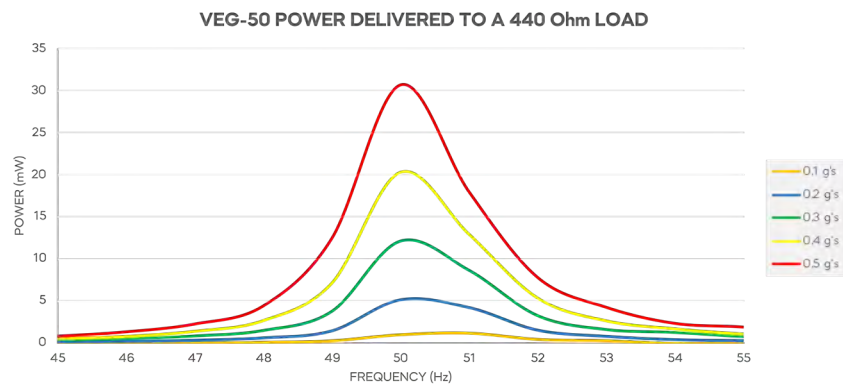
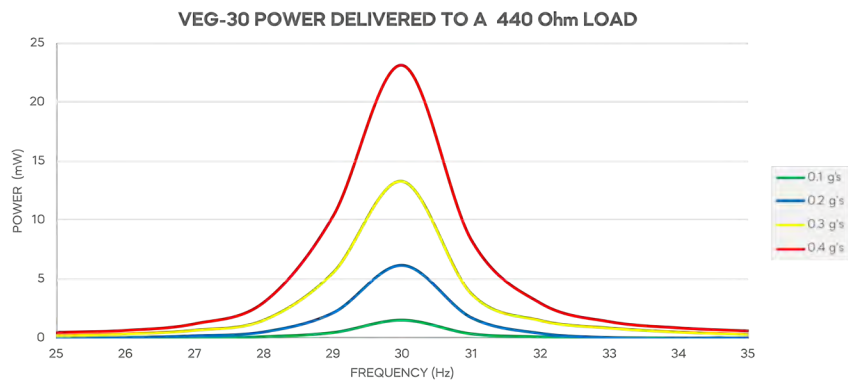
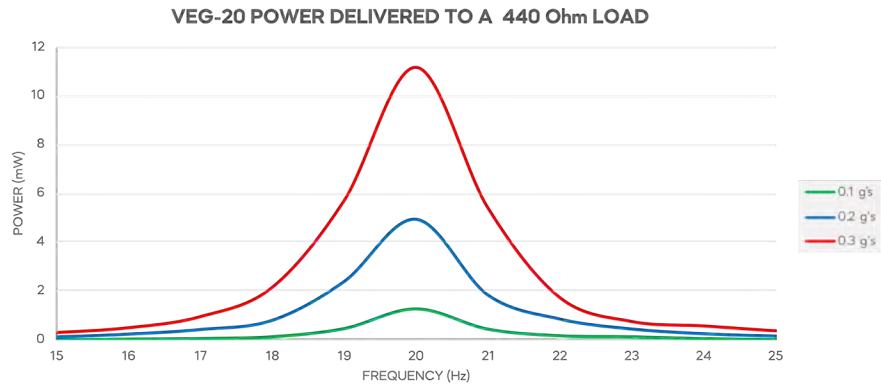

VEG-60 POWER DELIVERED TO A 440 Ohm LOAD

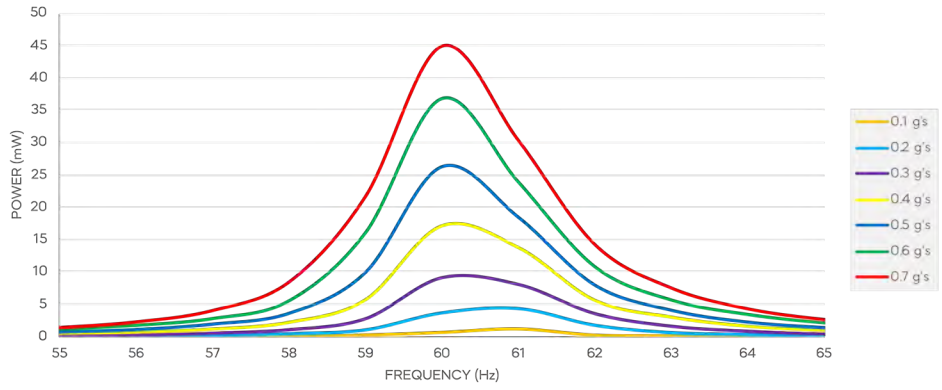

VEG-70 POWER DELIVERED TO A 440 Ohm LOAD

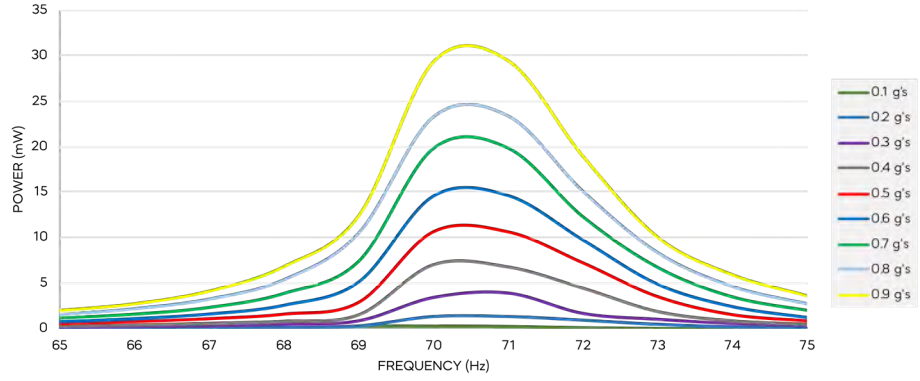

Design Guide

The VEG is offered with the intent to be designed within your wireless sensor enclosure. Including the VEG energy harvesting inside your wireless product can increase your solution's lifetime to 10+ years!



(a) Designed energy harvesting Orientation

(b) Orientation for no energy harvesting.

The generator radial center of mass should be placed near the center of mounting to the vibrating surface to ensure best efficiency of vibration energy transfer.

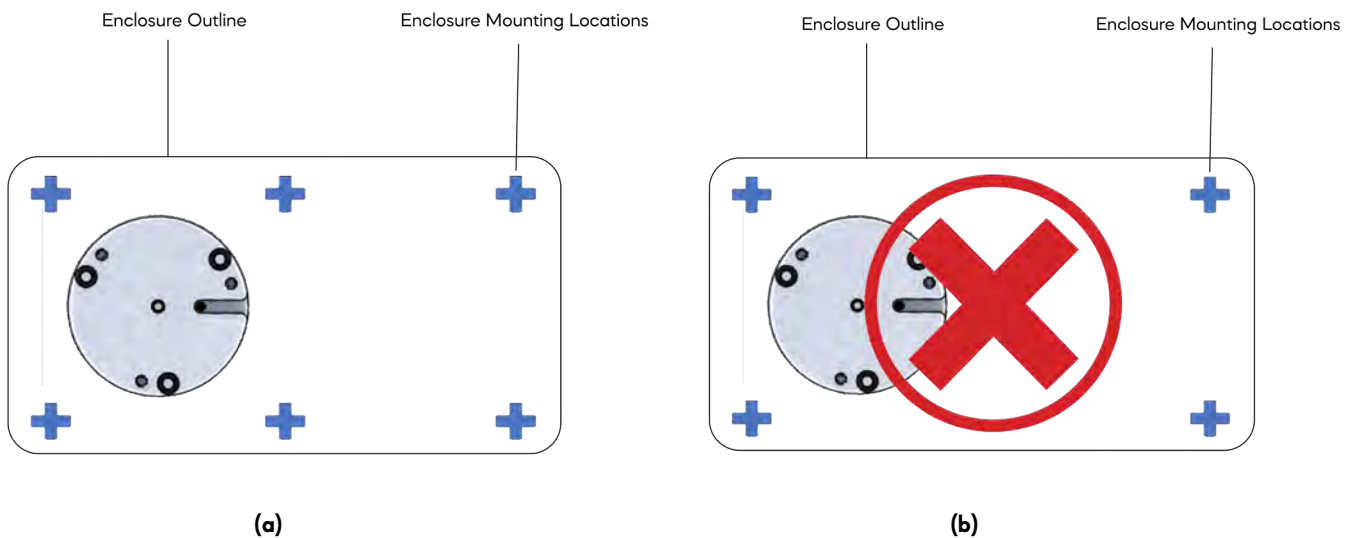

The generator has 3 tapped holes for 4-40 screws on the bottom. The recommended screws are metal with a Zinc coating or aluminum body with a maximum screwed in depth of 3.2mm. To maintain a well coupled interface during vibration, use of an adhesive in the threaded locations is advised. There should not be excess adhesive. Apply and cure the adhesive with the mounting side facing down. Use locking washers. For optimal power from the generator, the mounting plate threaded holes should be connected to the surface of the mounted vibrating surface by primarily metal components, to include the enclosure plate (as oppose to thin walls, joints, and plastics that have low stiffness).

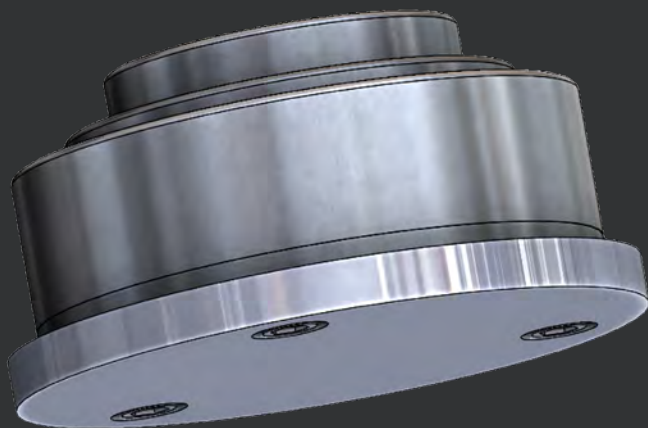

(a) Mounting configuration optimized for energy harvesting

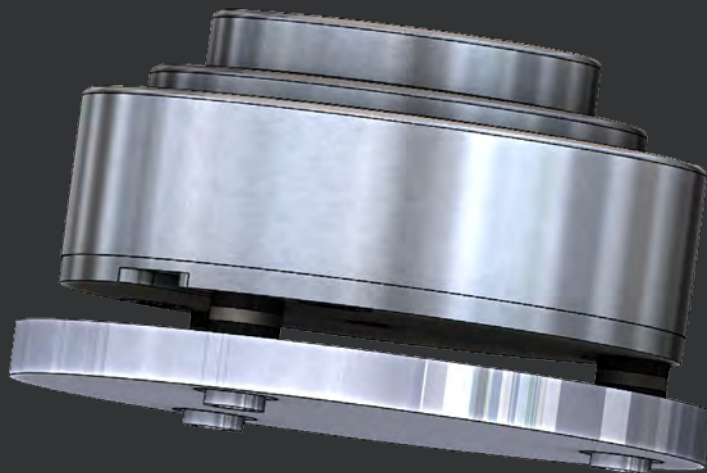

(b) Mounting configuration improved for sound isolation.

If the sensor is directly next to the vibration energy harvester, a noise of less than -50dB of the amplitude of the vibration may be detected because of the energy harvesting generator. However, if reduction of noise to a nearby sensor is required, composite supports may be used. The application of Acetal Copolymer/Steel/Acetal Copolymer/Enclosure/Acetal Copolymer washer system, per Figure 5, should result in a noise of less than -90dB from the vibration profile. In this case, a Zinc coated steel screw is recommended. If further noise reduction is required, the Xidas VP3 is recommended, which consists of this energy harvesting technology in a separate enclosure that provides power via a tether to a separate sensor enclosure.

Energy Harvesting Power Management and Storage

A variety of integrated circuit options are available to condition the output of the VP3 generator for specific applications. These power-management ICs use the electrical energy harvested from vibrations to generate regulated voltages and/or charge storage devices such as supercapacitors and batteries. Central to these integrated devices are ultralow quiescent current op-amps, regulators, and other components which provide high-efficiency conversion of the generator's output. Additional features may include boost converters to handle low voltage inputs, and maximum power-point tracking to optimize energy conversion.

Xidas has done this engineering for you. Our next-generation energy harvesting module (EHM) is specialized to condition and capture the maximum amount of power from energy harvesting generators (especially the VEG).

Additionally, Xidas offers optimal energy storage for the power generated from energy harvesting: a wide temperature, high-pulse, rechargeable battery (RHB-1530). This battery is tailored for wireless IoT solutions, with capabilities of handling high current pulses associated with transmitting data.

Xidas encourages leading sensor companies to incorporate these building blocks into their wireless sensing enclosures for a quick, direct, and cost-effective way to add energy harvesting capabilities and benefits. Each of these building blocks are also neatly packaged inside our VP3 (Vibration Perpetual Power Pod), for an all-in-one, plug-and-play solution. Please reach out for aid in the integration or development of your energy harvesting wireless sensor.

Vibration Energy Harvesting Generator **VEG**

Available as standalone Product

Energy Harvesting Module (Power Management) **EHM**

Available as standalone Product



Rechargeable High Puls Battery **RHB-1530**

Available as standalone Product

Ordering Information

Model Number	Part Number	Description
VEG-20	10-301000	Designed for 20 Hz vibration sources
VEG-30	10-301100	Designed for 30 Hz vibration sources
VEG-50	10-301200	Designed for 50 Hz vibration sources
VEG-60	10-301300	Designed for 60 Hz vibration sources
VEG-70	10-301400	Designed for 70 Hz vibration sources

consult factory for other frequencies

Complimentary Products

The VEG works best in conjunction with Xidas's energy harvesting module (EHM) and rechargeable high-pulse battery. Here is how to order:

High Efficiency, Universal Energy Harvesting Module



Model Number	Part Number	Description
EHM-UNIV-1	10-301500	Energy Harvesting Module-Universal

Rechargeable High-Pulse Battery



Model Number	Part Number	Description
RHB-1530	86000000	Rechargeable High-pulse Battery

Vibration Perpetual Power Pod



Model Number	Part Number	Description
VP3-20	10-300400	Designed for 20 Hz vibration sources
VP3-30	10-300100	Designed for 30 Hz vibration sources
VP3-50	10-300300	Designed for 50 Hz vibration sources
VP3-60	10-300200	Designed for 60 Hz vibration sources



xidas.com 代理商联系方式:

样品, 报价, 评估板, 参考设计, 技术支持

电话: 0755-82565851

邮件: dwin100@dwintech.com

手机: 156-2521-4151

网址: www.dwintech.com/xidas_inc.html

深圳市南频科技有限公司

D-Win Technology (HongKong) Co., Ltd